

McIntosh

MX 112

FM/AM TUNER PREAMP

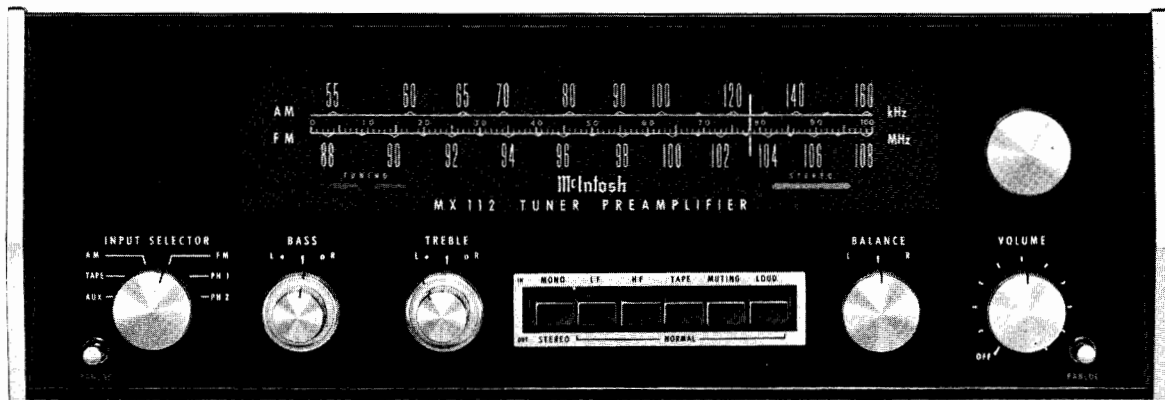

SERVICE INFORMATION

FROM SERIAL NO. 10S01 TO 39S99

McINTOSH LABORATORY INC. 2 CHAMBERS STREET BINGHAMTON, NEW YORK

MX 112

ELECTRICAL SPECIFICATIONS

FM TUNER SECTION

USABLE SENSITIVITY

Better than 2.5 μ F (IHF usable sensitivity)

SIGNAL TO NOISE RATIO

Better than 65dB

HARMONIC DISTORTION

Mono, less than 0.5%. Stereo, less than 0.8%.

FREQUENCY RESPONSE

Flat from 20Hz to 20kHz with standard de-emphasis and 19kHz pilot filter

CAPTURE RATIO

Better than 1.5dB

SPURIOUS REJECTION

90dB or greater

IMAGE REJECTION

75dB or greater (at 100MHz)

STEREO SEPARATION

Better than 30dB at 1kHz

AM TUNER SECTION

SENSITIVITY

Better than 12 μ V at 1000kHz (using external antenna input)

SIGNAL TO NOISE RATIO

Better than 55dB

HARMONIC DISTORTION

Less than 1% at 30% modulation

FREQUENCY RESPONSE

Down 6dB at 5kHz

SELECTIVITY

10kHz at -6dB

IMAGE REJECTION

60dB or greater at 1000kHz

PREAMPLIFIER SECTION

FREQUENCY RESPONSE

\pm 0.5dB, 20Hz to 20,000Hz

DISTORTION

Less than 0.1% at 2.5 volts 20Hz to 20kHz

INPUT SENSITIVITY (phono 1 and phono 2)

2 millivolts for 2.5 volts output at 1kHz

INPUT SENSITIVITY (aux, tape)

0.25 volts for 2.5 volts output

HUM AND NOISE (phono 1 and phono 2)

72dB below 10 millivolt input

HUM AND NOISE (aux, tape)

85dB below rated output

OUTPUT (main)

2.5 volts with rated input. Up to 10 volts can be developed without distortion. FM and AM will produce up to 10 volts output at 100% modulation.

OUTPUT (tape)

0.25 volts with rated input. Phono input signal of 10 millivolts produces 1.2 volts output. FM and AM will produce 1 volt output at 100% modulation.

OUTPUT (center channel)

2 volts with rated input to both channels

BASS CONTROL

-18dB to +16dB at 20Hz

TREBLE CONTROL

\pm 20dB to 20,000Hz

LF FILTER

Flat or roll off below 50Hz, down 12dB at 20Hz

HF FILTER

Flat or roll off above 5000Hz, down 12dB at 20,000Hz

FM/AM TUNER SECTION

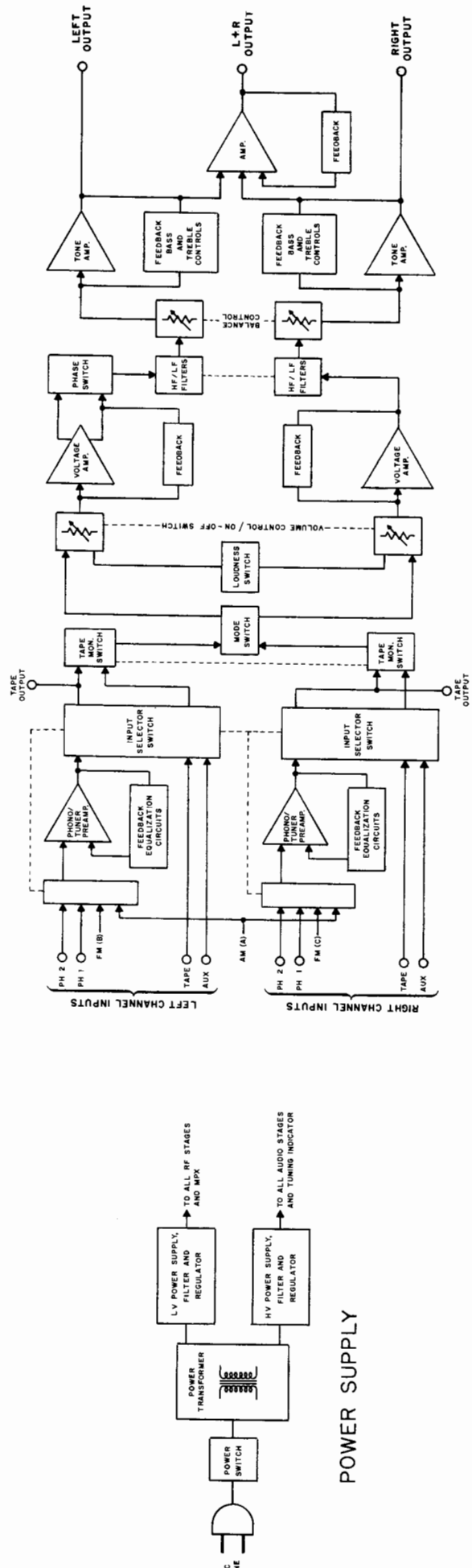
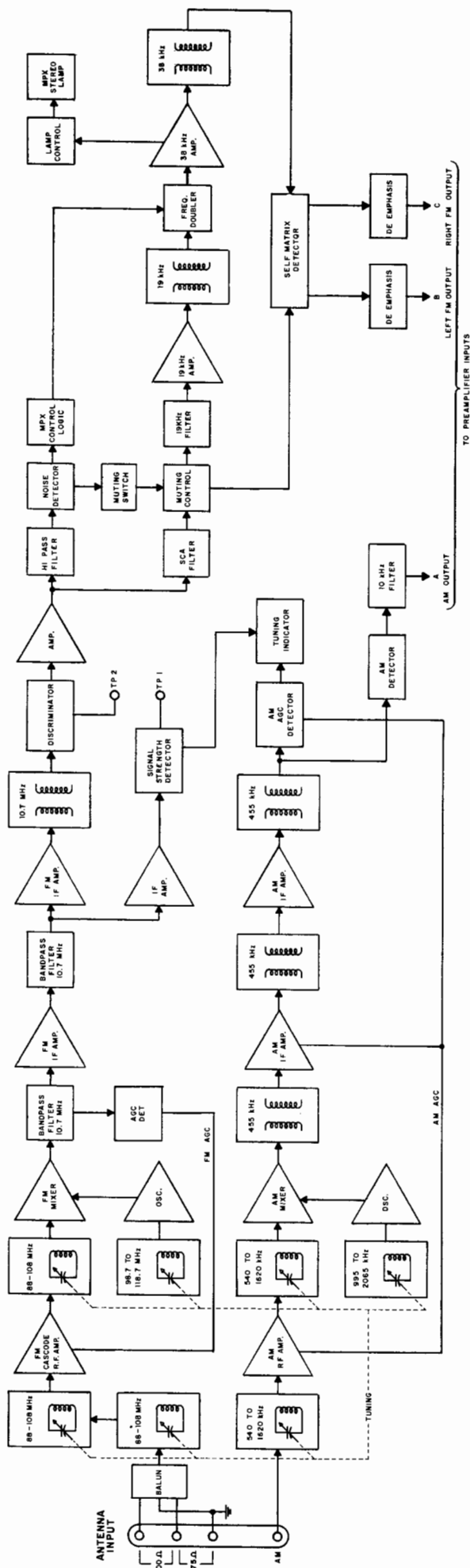

PREAMPLIFIER SECTION

MX 112 BLOCK DIAGRAM

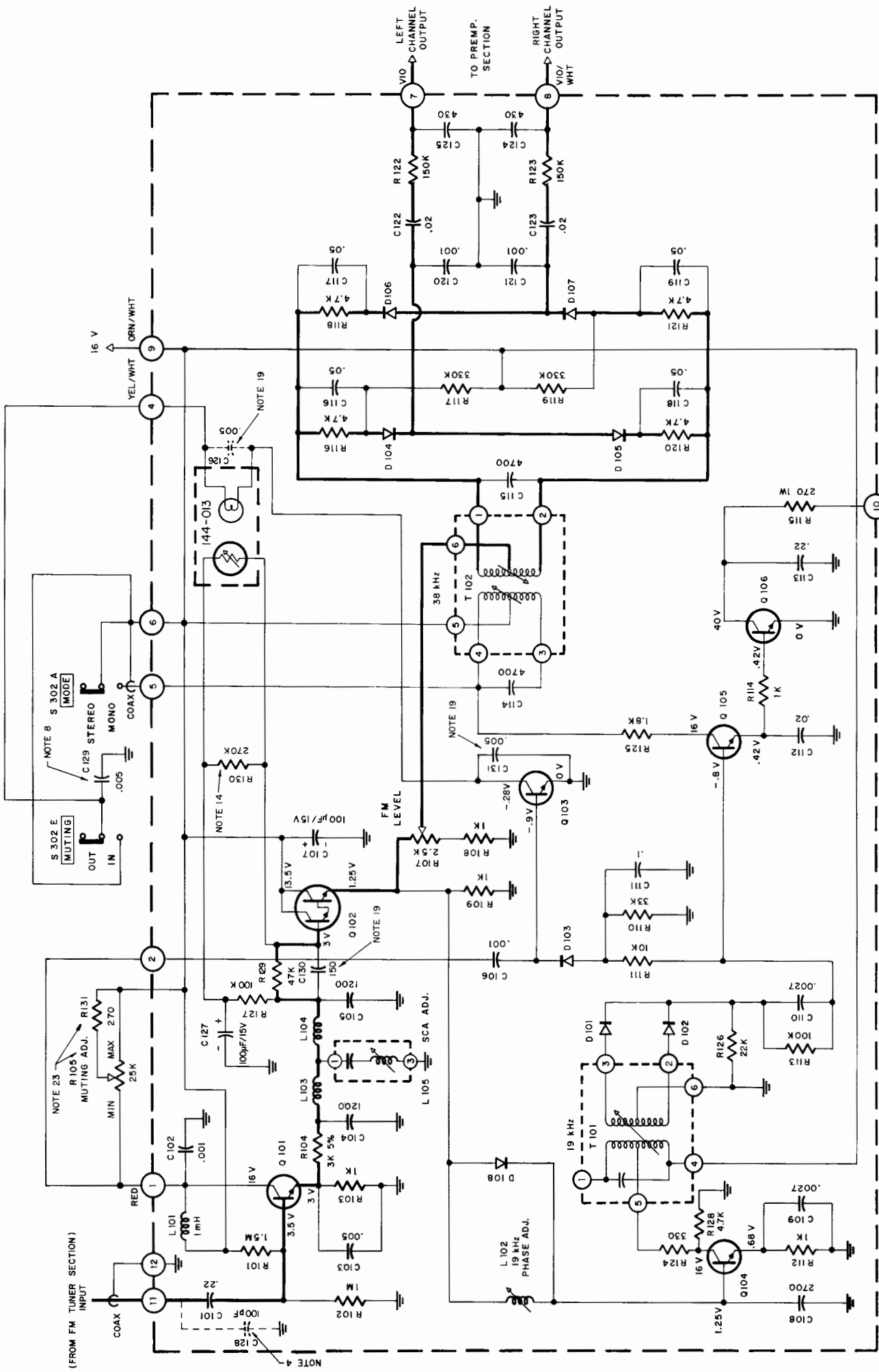

MPX PRINTED CIRCUIT BOARD 043-974

MPX SECTION
MX 112
154-438

MPX LIGHT
*1828

RF CHASSIS

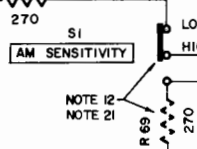
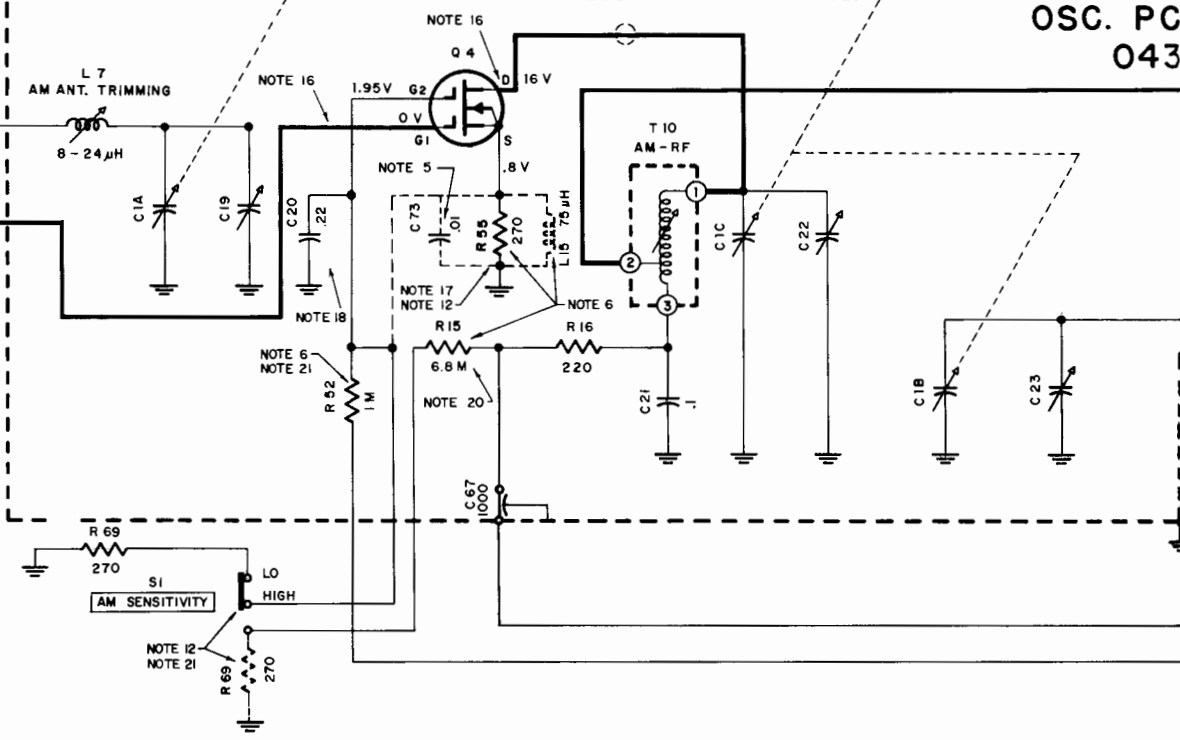
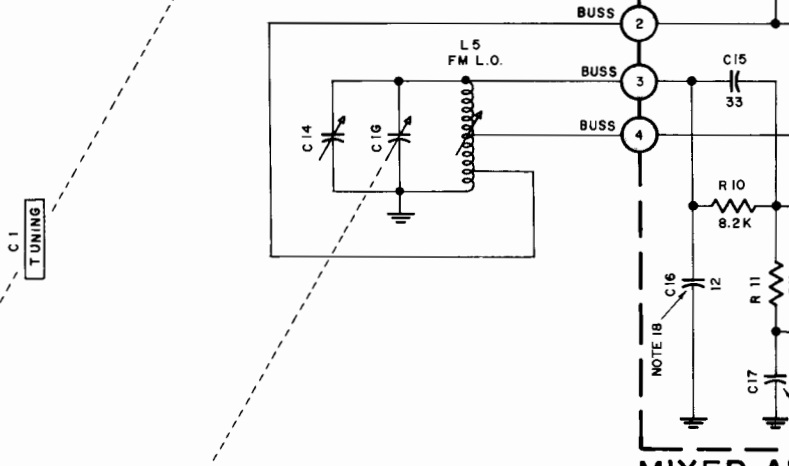
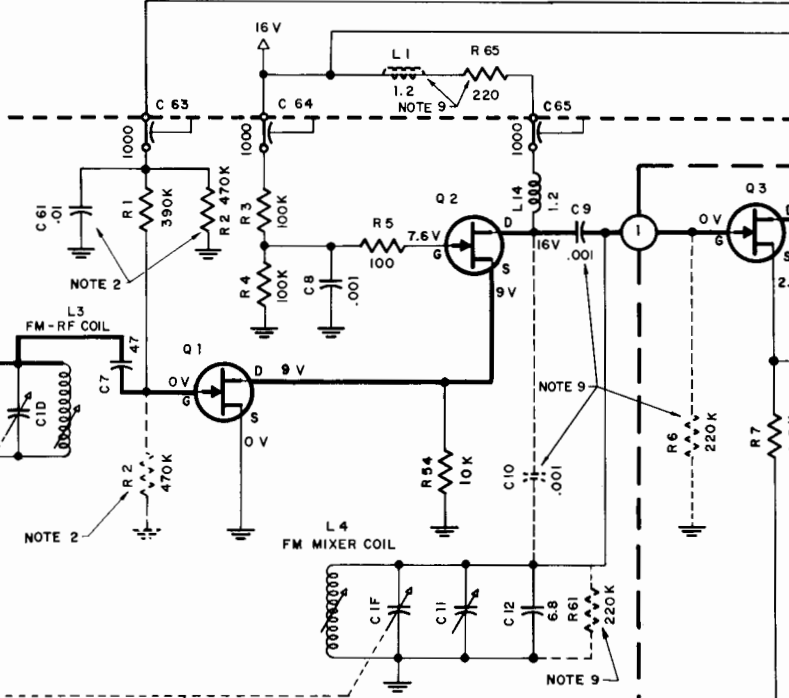
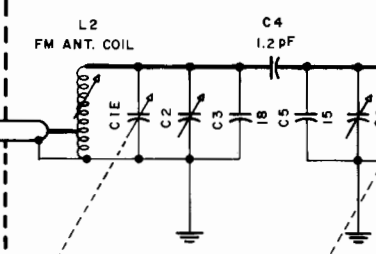
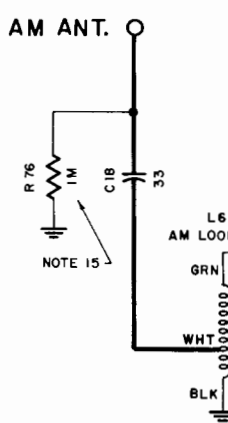
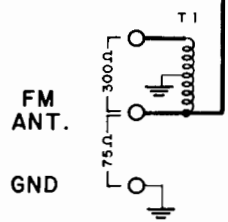

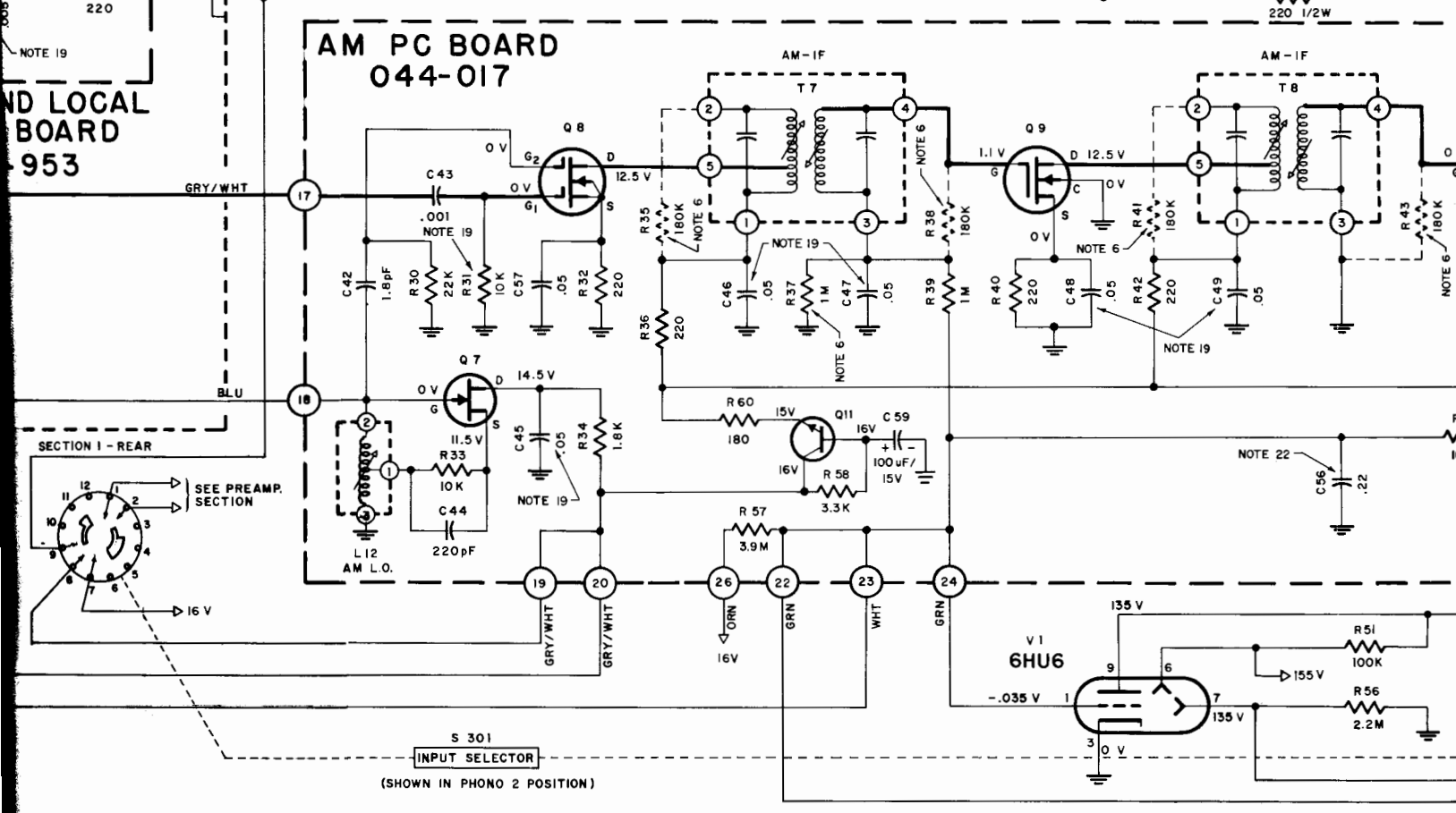
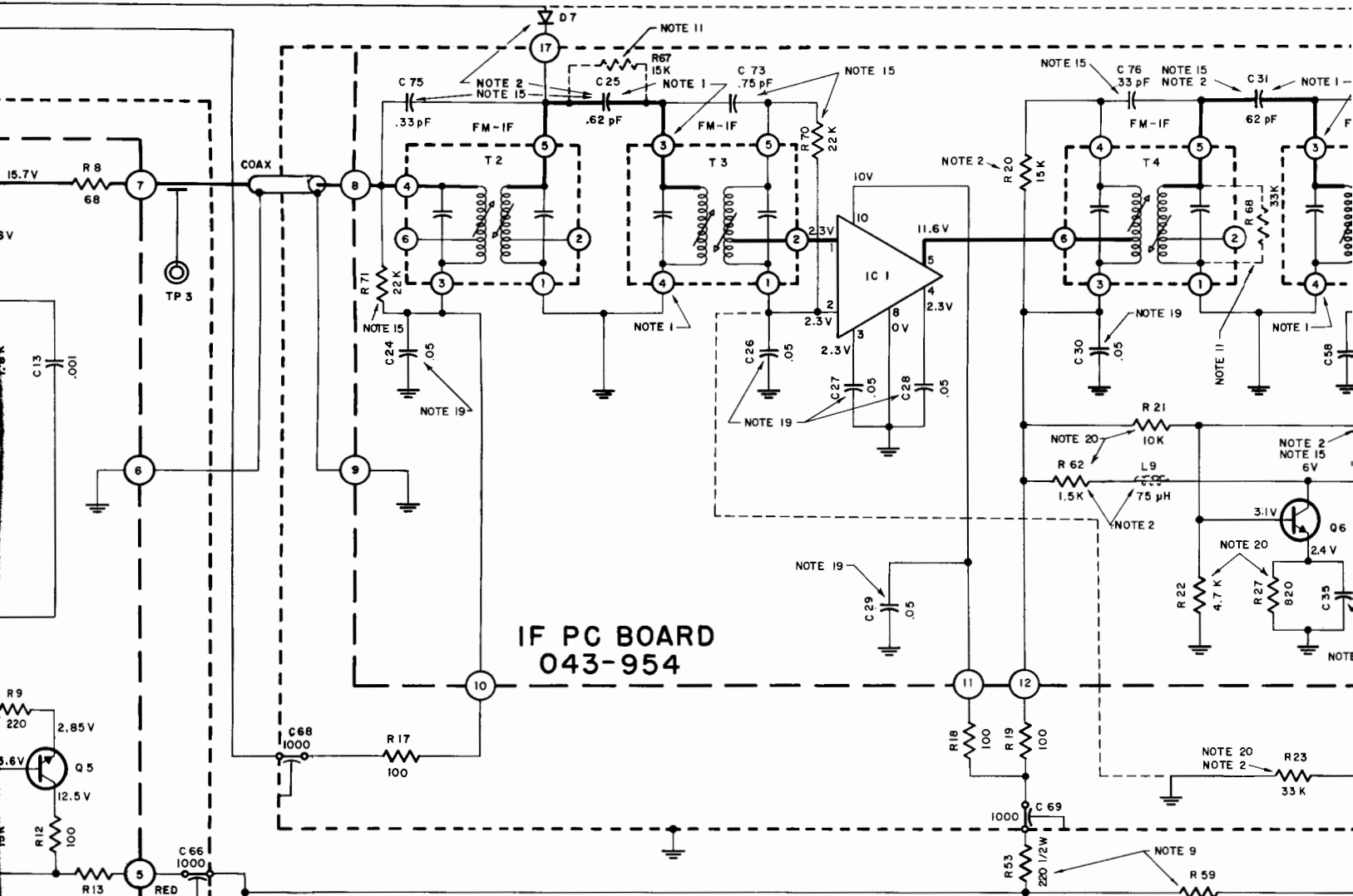

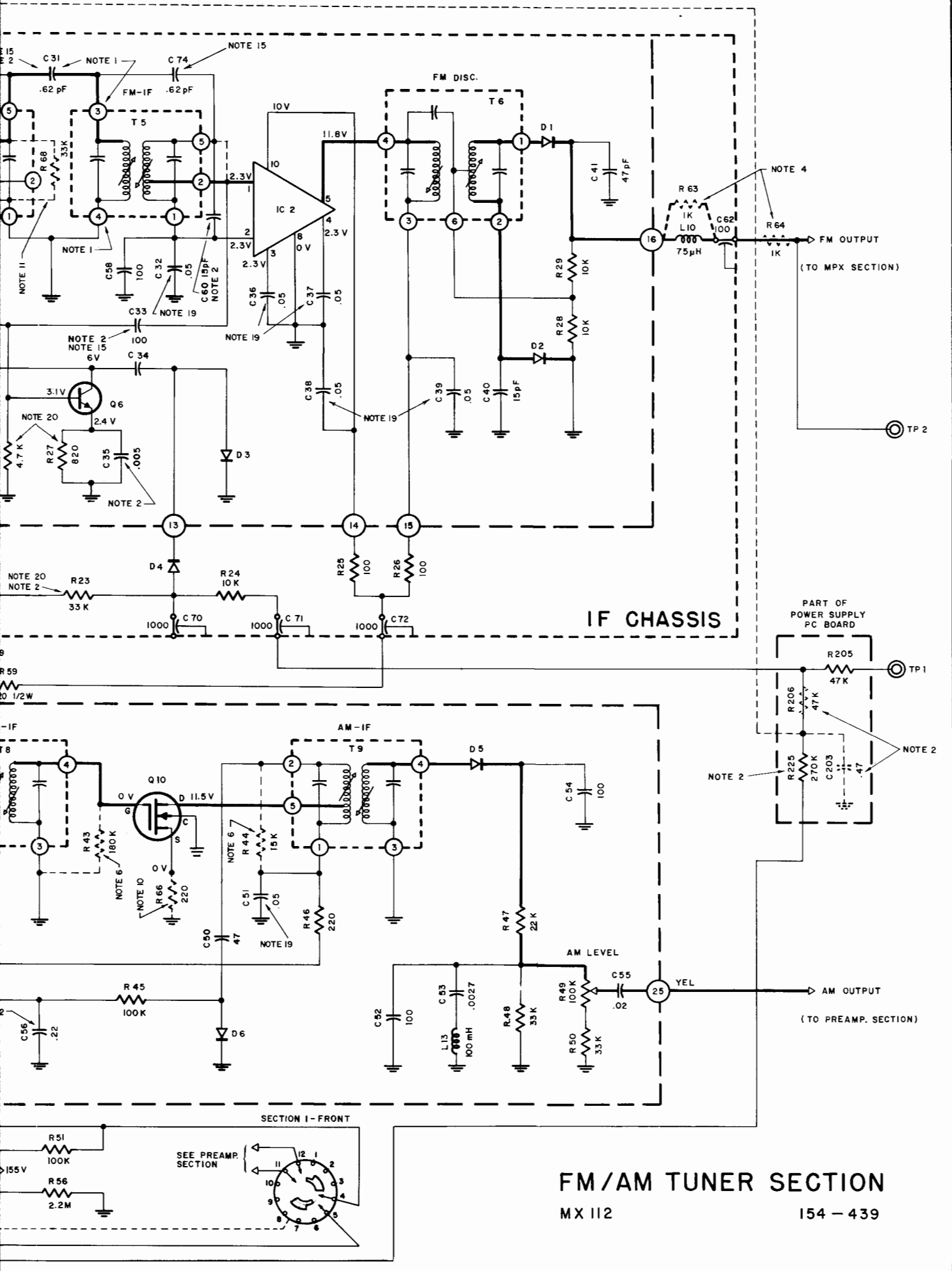

FM/AM TUNER SECTION
MX 112 154 - 439

SCHEMATIC NOTES

Unless otherwise specified: Resistance values are in ohms, 1/4 watt, and 10% tolerance; capacitance values smaller than 1 are in microfarads (μF); capacitance values greater than 1 are in picofarads (pF); inductors are in microhenries (μH).

Printed circuit board components are outlined on the schematics by dotted lines. The circled numbers around the dotted lines correspond to the numbers on the PC Board layouts.

The heavy lines on the schematics denote the primary signal path.

The terminal numbering of rotary switches is for reference only.

All voltages indicated on the schematics are measured under the following conditions:

- Use of an 11 megohm input impedance VTVM.
- All voltages $\pm 10\%$ with respect to chassis ground.
- No signal at input or antenna terminals.
- AC input at 117 volts, 50/60Hz.
- Front panel controls at:

Tuning indicator	100MHz (no signal)
Volume	Fully CCW
Mode	Stereo
Muting	Out
Input Selector	AM (to measure AM section) FM (to measure FM section)
Panel Lights	Bright

- In units with serial numbers below 11S00: C25 is connected to pin 4 of T3; pin 3 of T3 is connected to ground; C31 is connected to pin 4 of T5; pin 3 of T5 is connected to ground.
- In units with serial numbers below 11S17: C25 and C31 are $2.2\mu\text{F}$; C33 is 6.8pF and is connected to pin 5 of T5; C35 is $.001\mu\text{F}$; C60 is not used; R20 is 33k ; R23 is 33k and is connected as shown by dotted line; L9 (part number 122-013) is used in place of R62; D7 and C61 are not used; R225 is 470k ; R206 and C203 (part number 064-069) are used and are connected as shown by dotted line. R2 is connected to the other end of R1 as shown by dotted line.
- R221 is used in units with serial numbers below 14S01.
- In units with serial numbers from 17S40 to 22S65: R63 is used in place of L10; R64 and C128 are used.
- In units with serial numbers from 17S25 to 17S75, C73 is used.
- In units with serial numbers below 17S25: R35, R38, R41, R43, and R44 are used; L15 is used; R37 is 470k ; R55 is 1k ; R52 is 1M and R15 is 6.8M .
- In units with serial numbers below 17S40: C345 is used; R397 and R398 are not used.
- In units with serial numbers below 18S35, C129 is not used.
- In units with serial numbers below 20S00: R53 and R59 are 100Ω ; R65 is not used; L1, R6, R61, and C10 are used; there is no connection from C12 to pin number 1 on the mixer and local oscillator PC Board; and C7 is connected to L3 as shown by dotted line.
- In units with serial numbers from 19S63 to 31S34, R66 is used.
- In units with serial numbers from 20S72 to 31S35, R67 and R68 are used.
- In units with serial numbers below 26S01: R55 is 270Ω ; R69 and S1 are not used.
- In units with serial numbers below 25S11, R399 and R400 are not used.

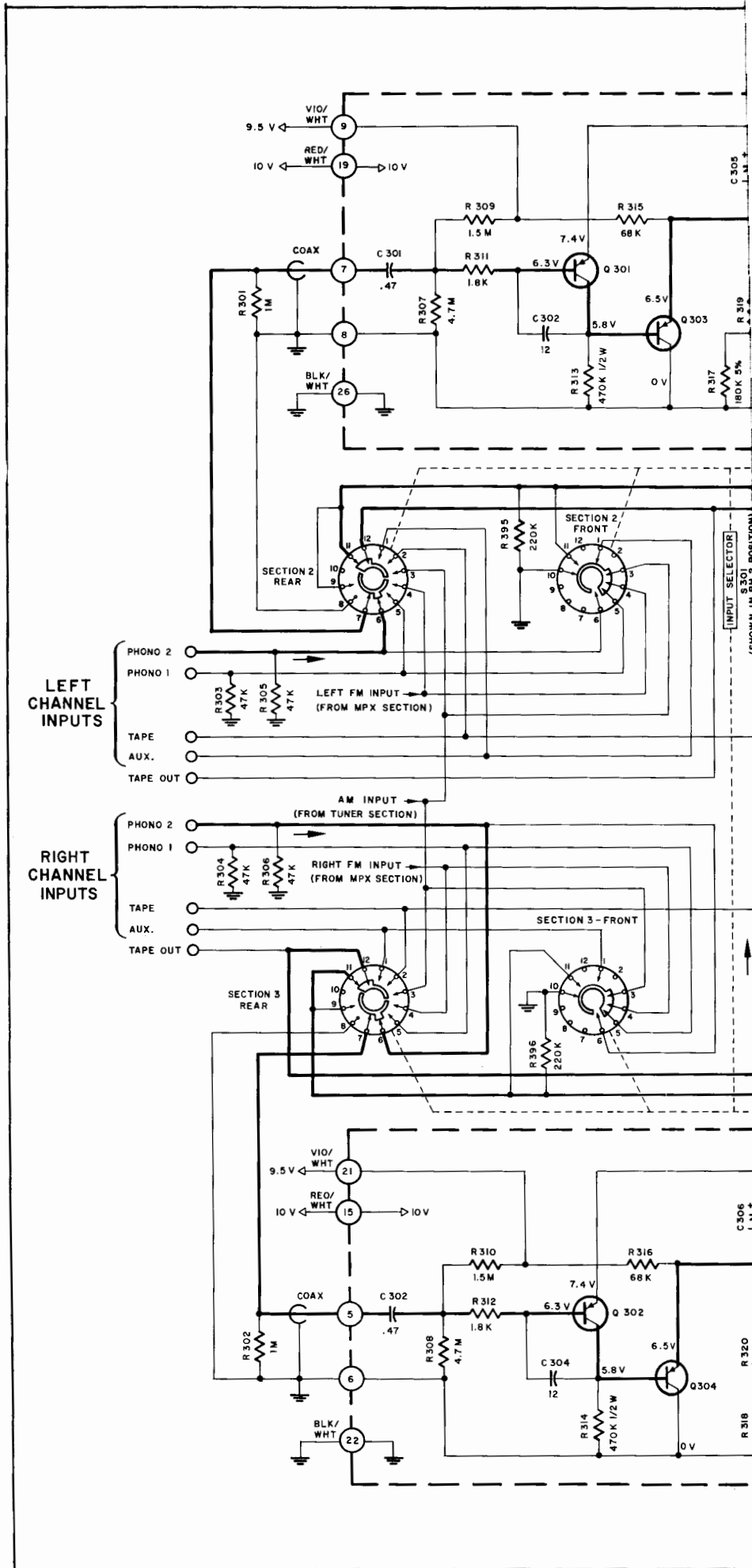

LEFT CHANNEL PREAMP. PRINTED C

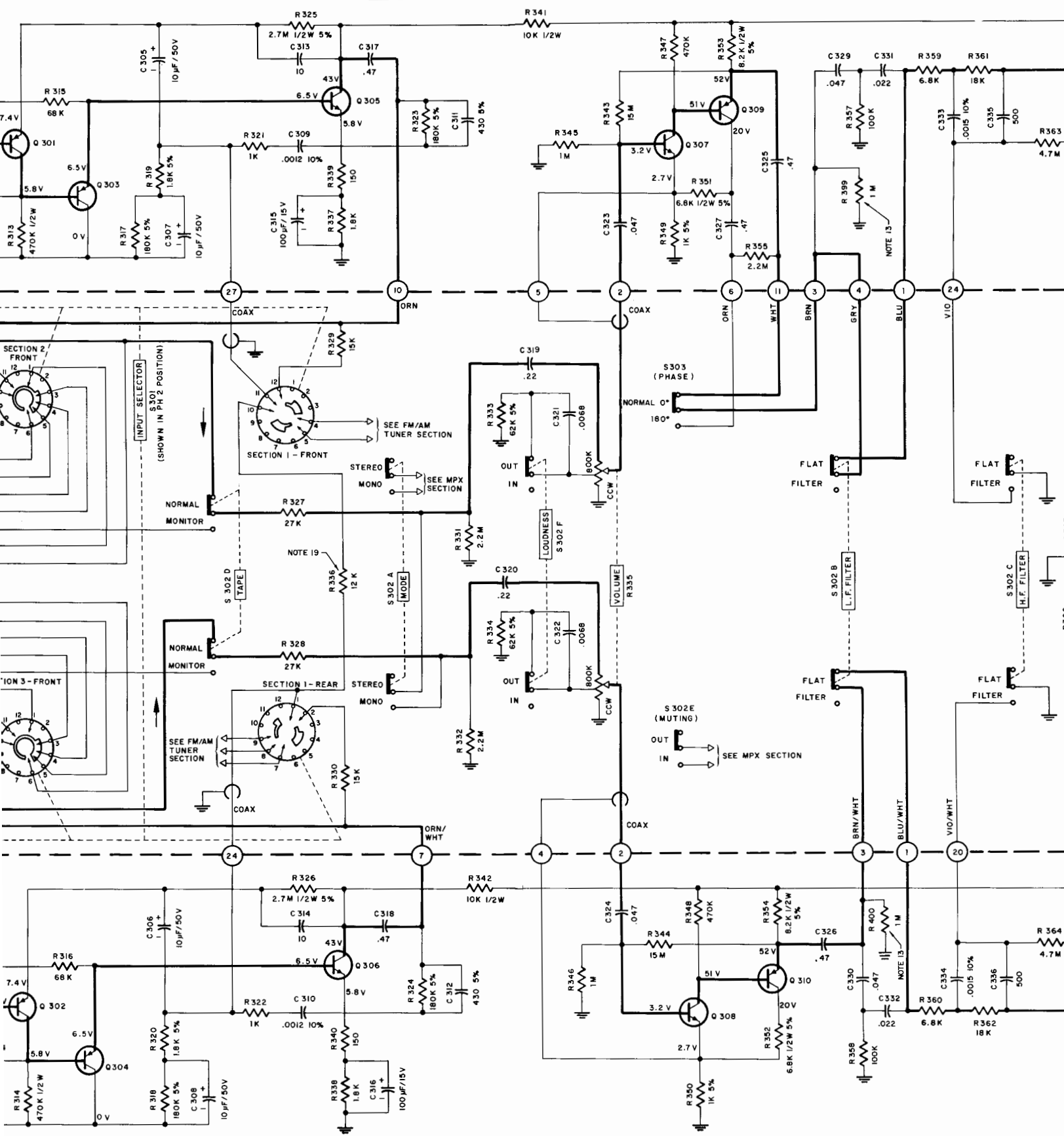

RIGHT CHANNEL PREAMP. PRINTED C

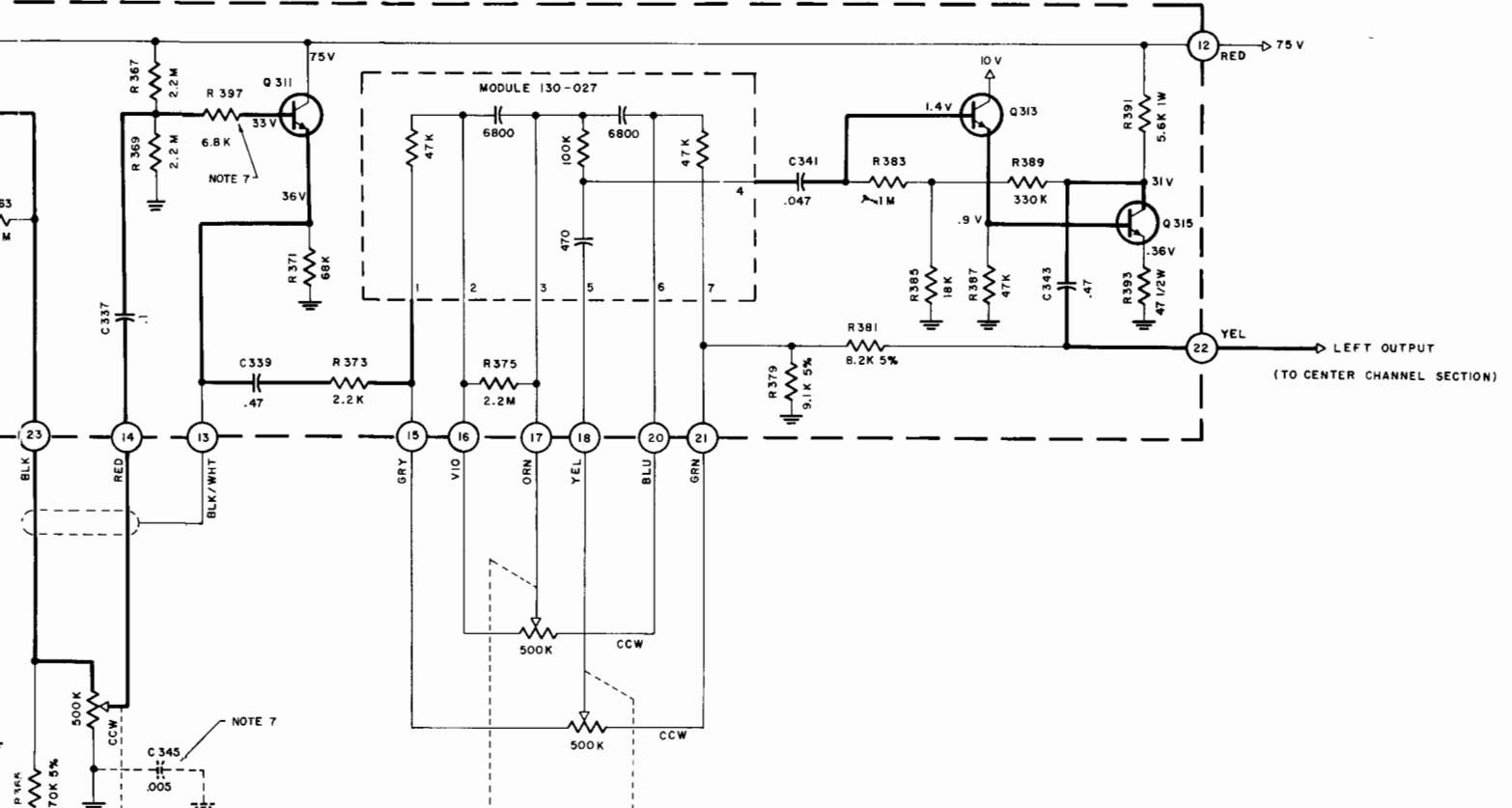

PREAMP. SECTION
MX 112 154-440

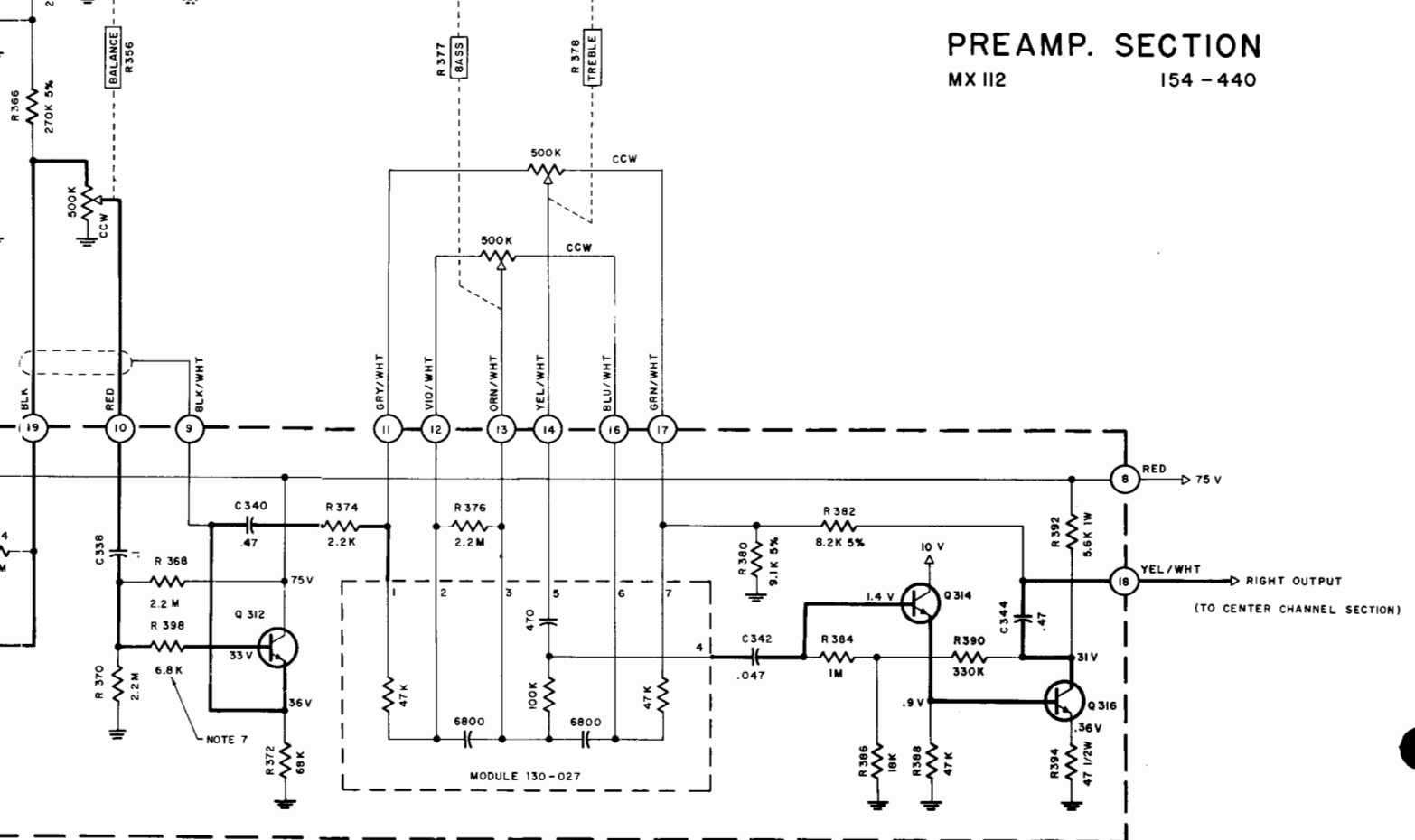

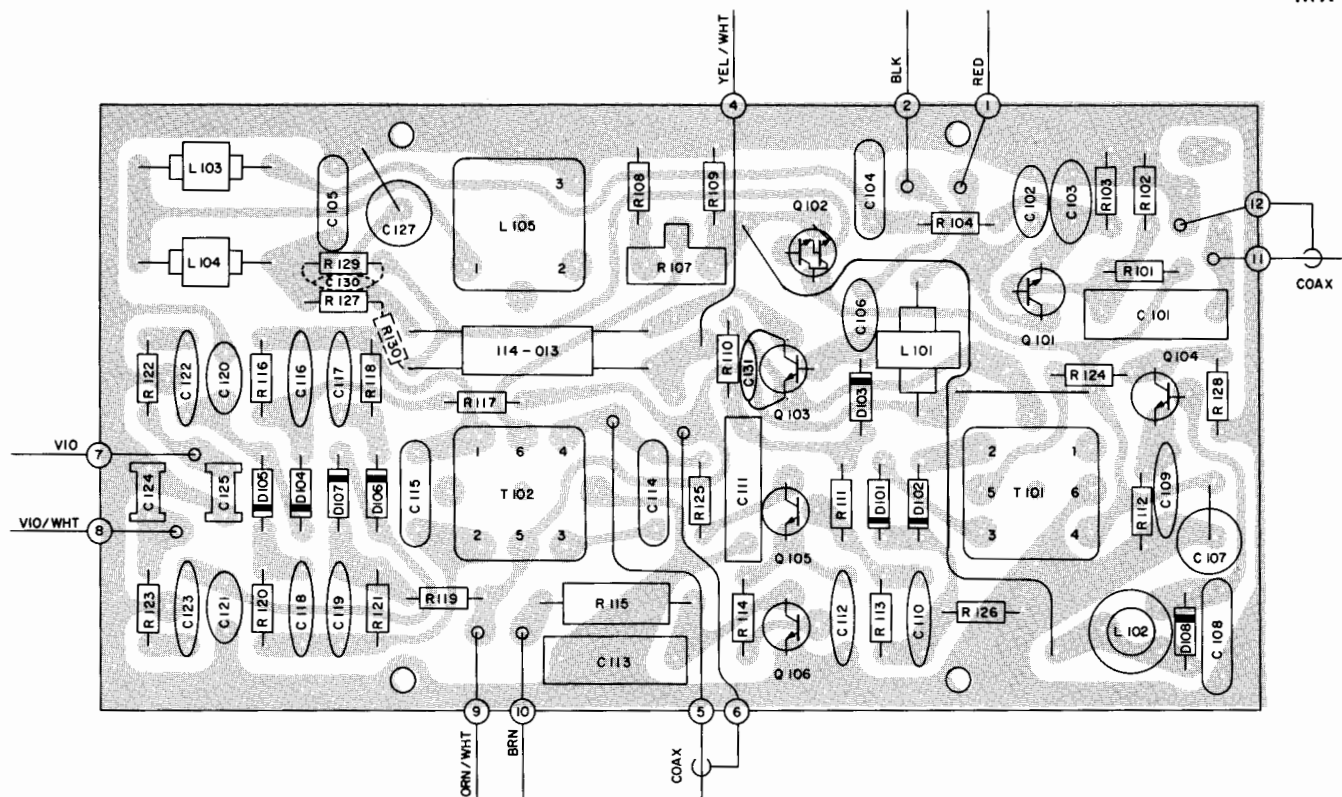

MPX PRINTED CIRCUIT BOARD 043-974

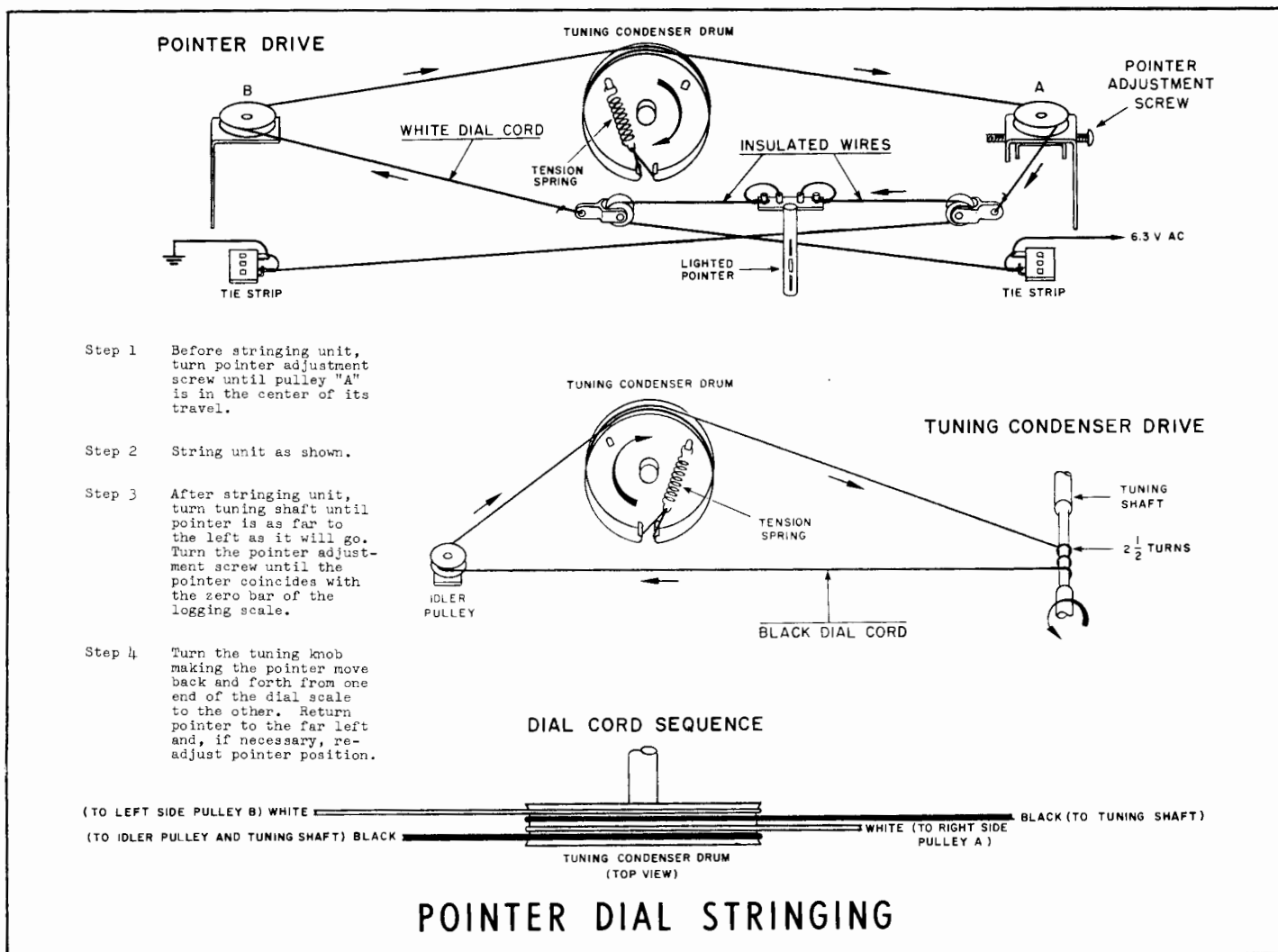

MIXER AND LOCAL OSCILLATOR P.C. BOARD
043-953

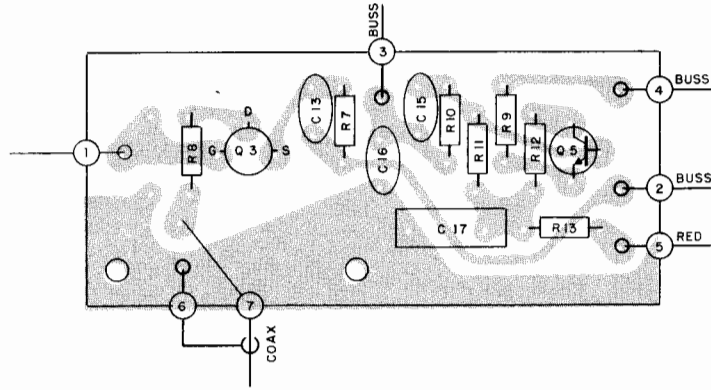

IF PRINTED CIRCUIT BOARD 043-954

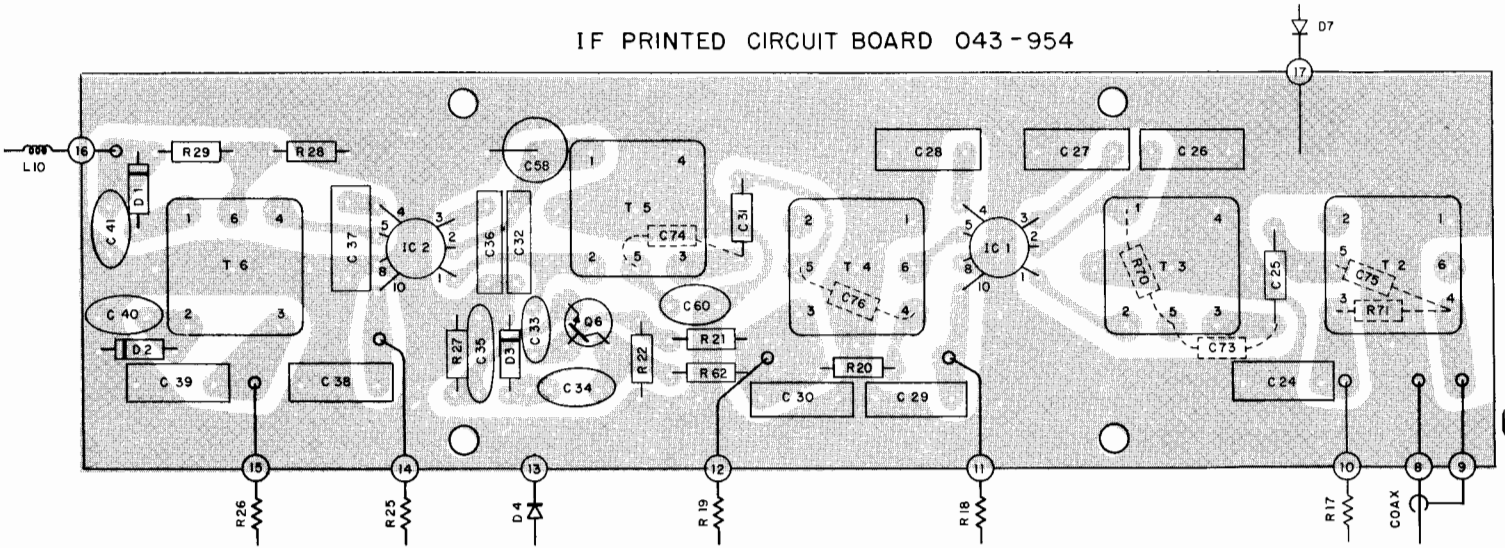

AM PRINTED CIRCUIT BOARD 044-017

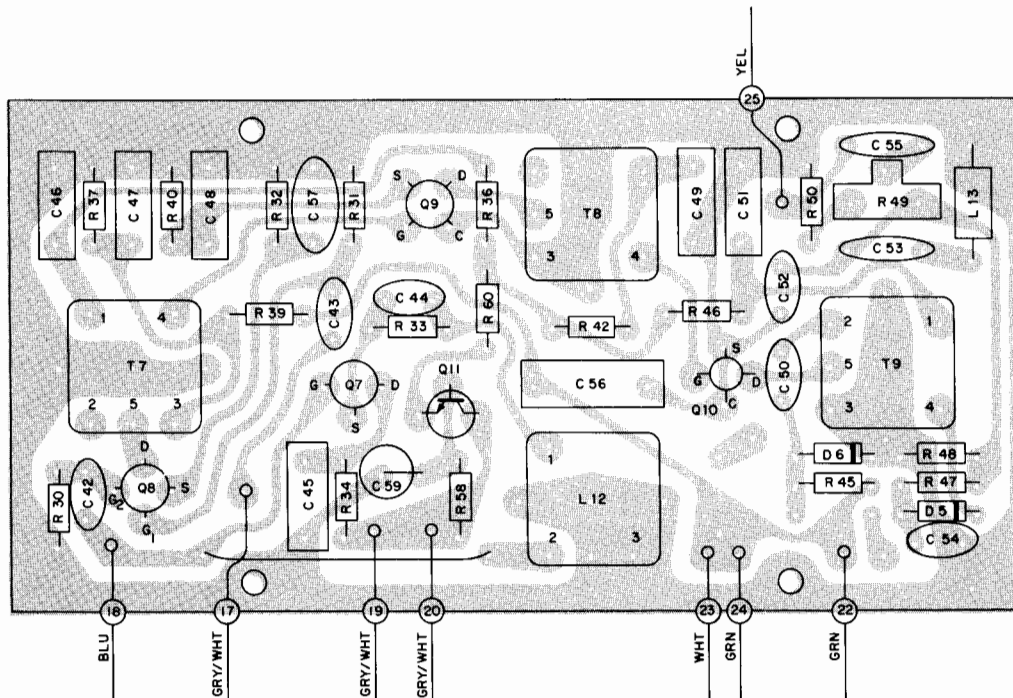

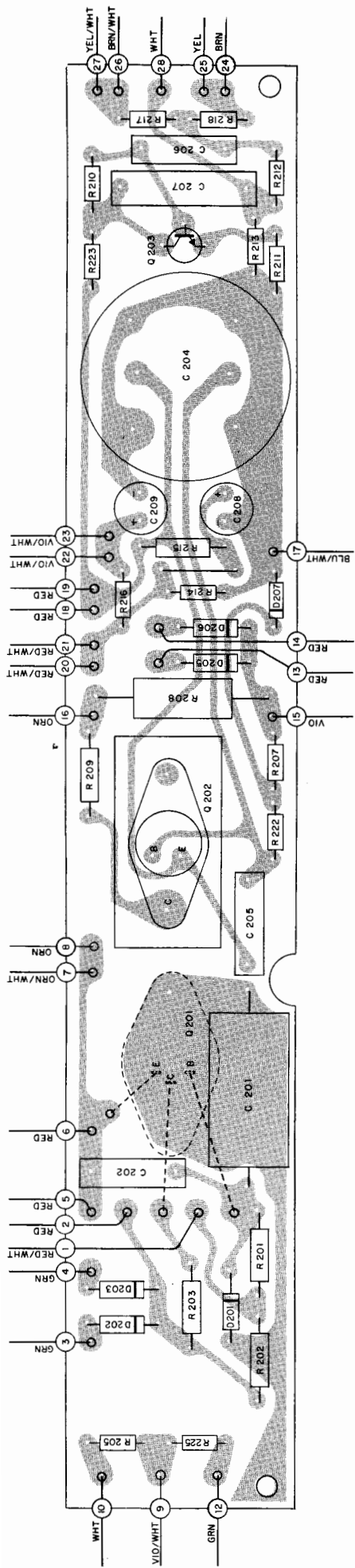

POWER SUPPLY / CENTER CHANNEL PRINTED CIRCUIT BOARD 043 - 983

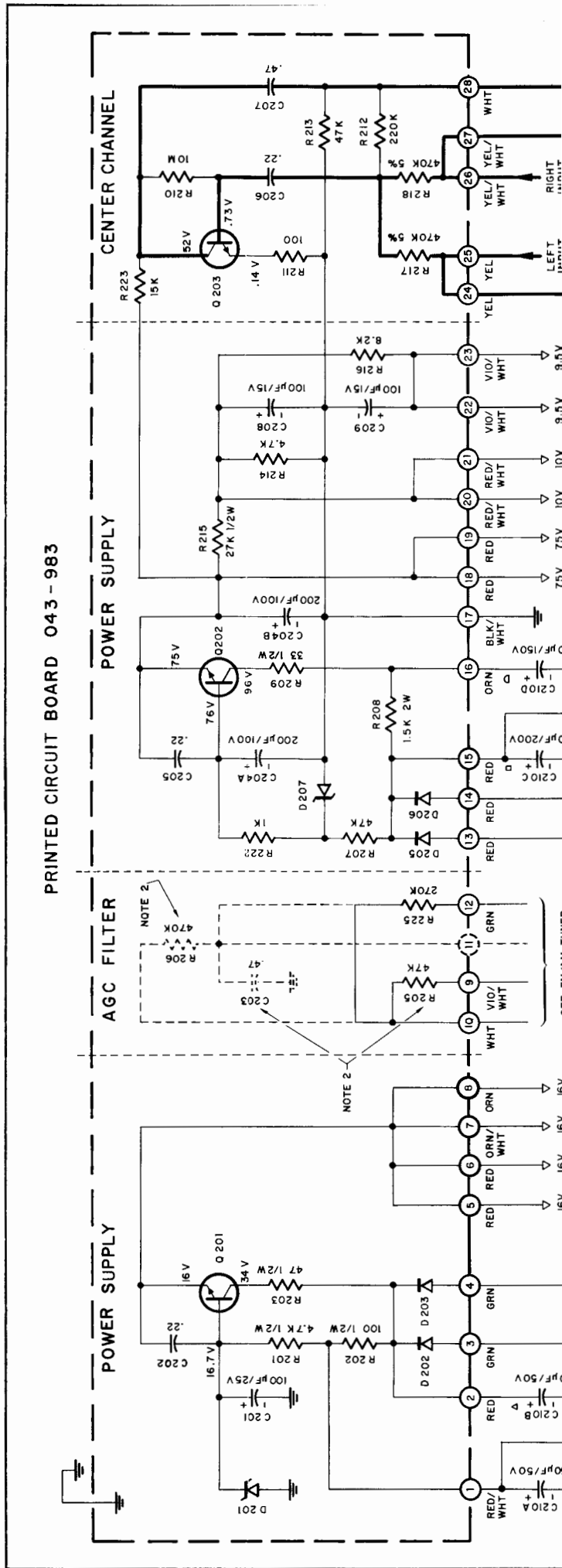

SCHEMATIC NOTES (CONT.)

14. In units with serial numbers below 31S34, R130 is not used.
15. In units with serial numbers below 31S35: C25 is 1.2pF; C31 is 1.5pF; C33 is .001 μ F; C73, C74, C75, C76, R70, R71, R72, and R226 are not used.
16. In units with serial numbers below 31S35, the drain of Q4 is connected directly to pin 17 on the AM PC Board and gate 1 of Q4 is connected directly to C19.
17. In units with serial numbers from 26S01 to 31S35, R55 is 56k.
18. In units with serial numbers below 31S35, C20 is .01 μ F.
19. In units with serial numbers below 31S56: R31 is 100k; R336 is 18k; C126 is used; C130 and C131 are not used; C17, C24, C26, C27, C28, C29, C30, C32, C36, C37, C38, C39, C45, C46, C47, C48, C49, and C51 are .047 μ F.
20. In units with serial numbers below 31S56: R23 is 15k; R27 is 1.5k; R62 is 2.7k, and R15 is 1M.
21. In units with serial numbers below 31S68, R57 is used; R52 is 100k and the AM sensitivity switch is wired as shown by dotted lines.
22. In units with serial numbers from 31S35 to 31S86, C56 is 1.5pF.
23. In units with serial numbers below 37S50, R131 is not used and R105 is a 200k potentiometer (McIntosh part number 134-205).

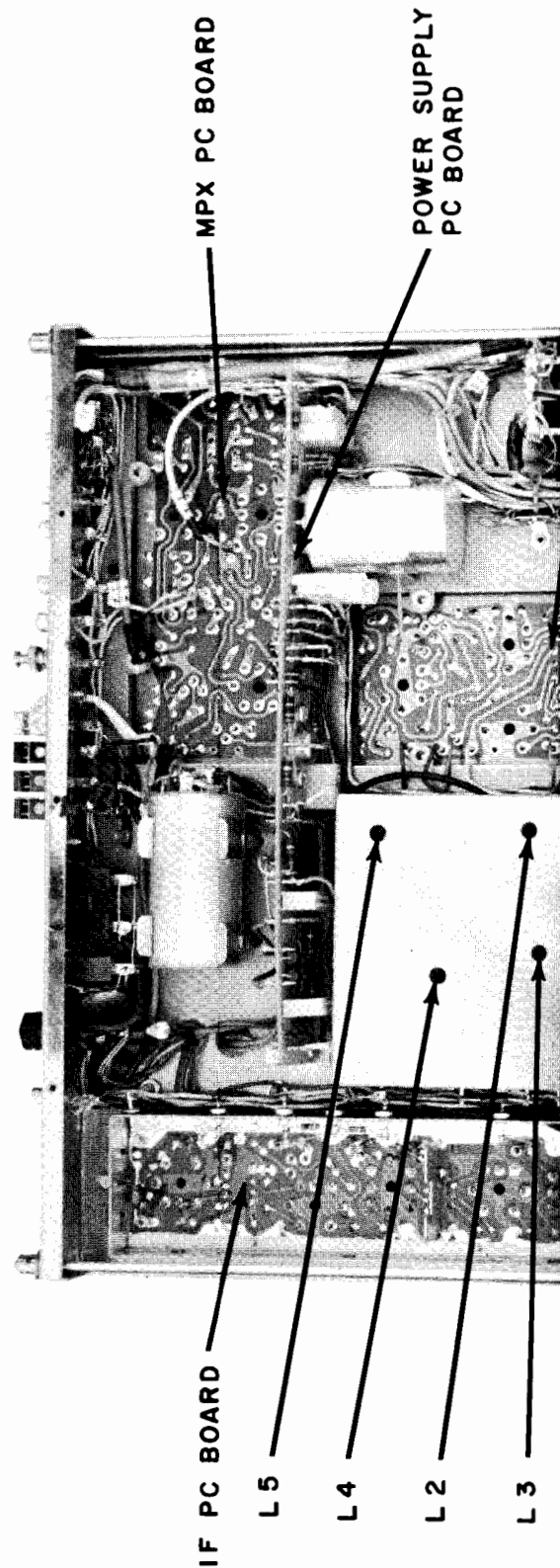

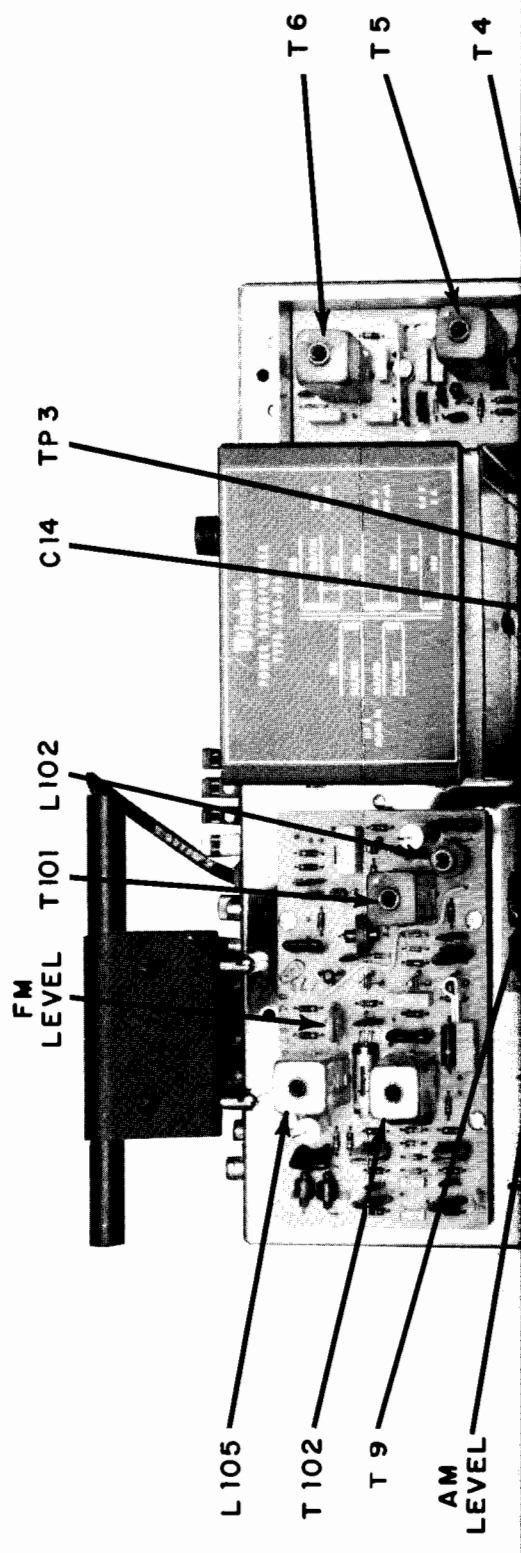
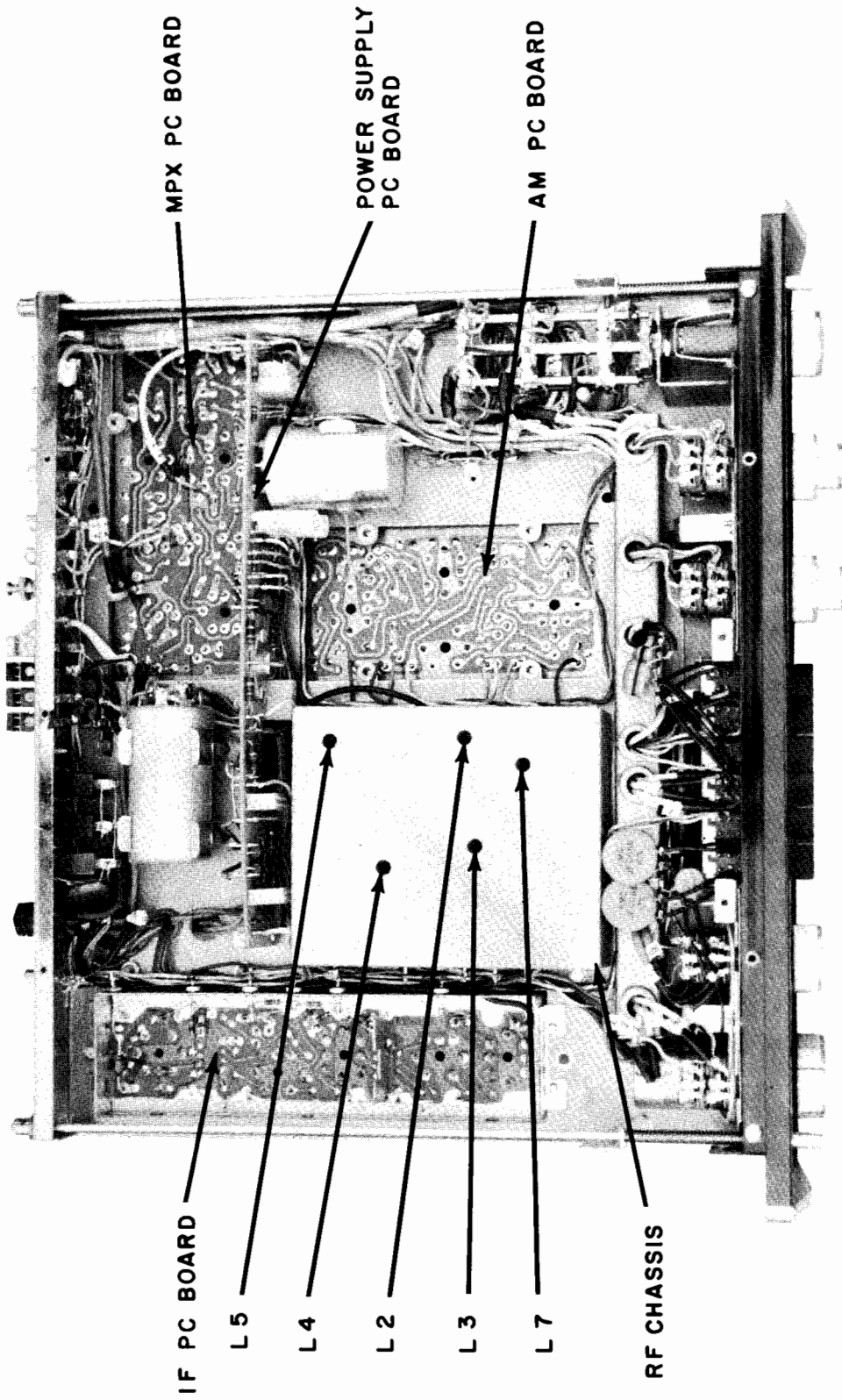

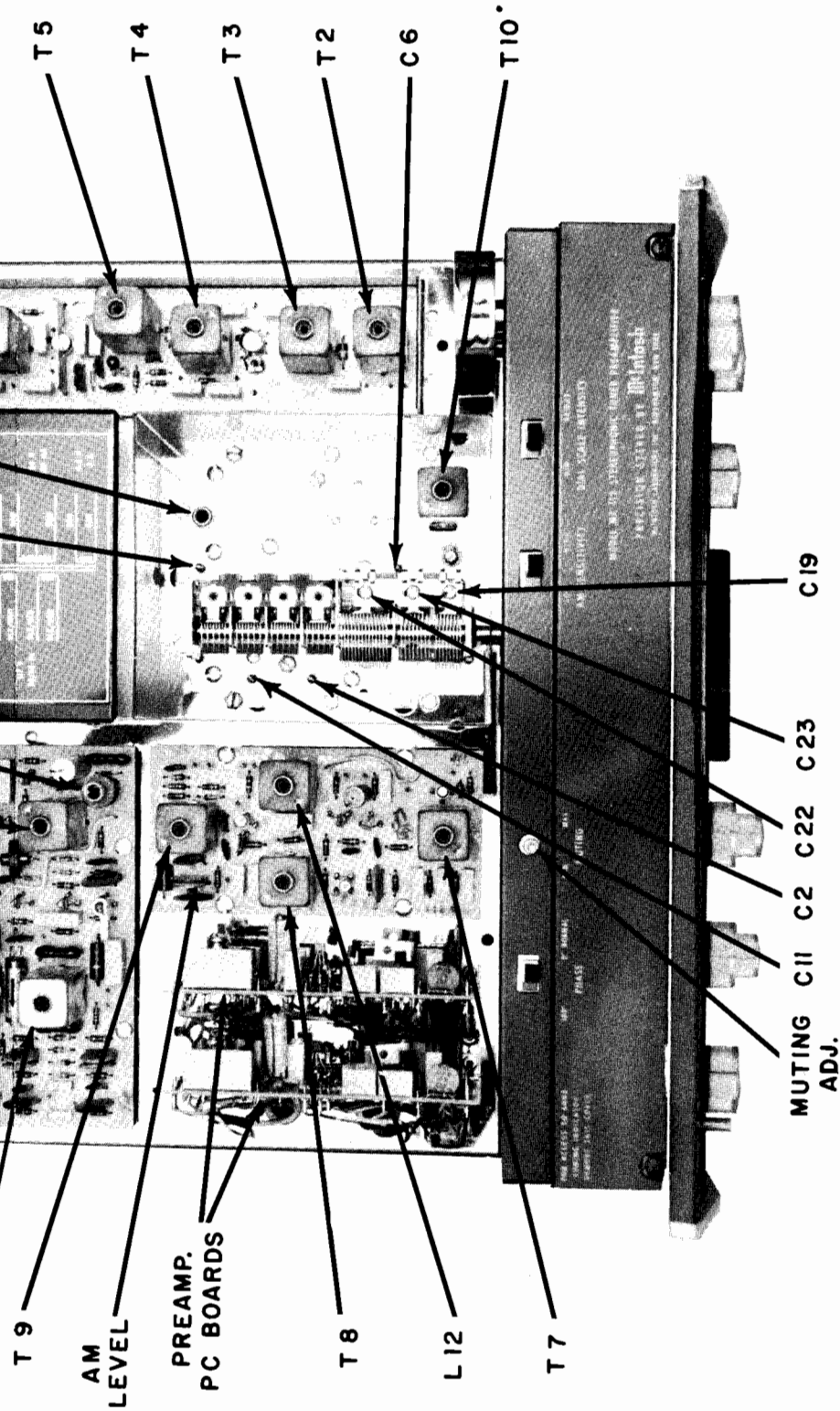

MX 112 ALIGNMENT INSTRUCTIONS

All McIntosh tuners are carefully aligned and tested at the factory using the finest available test equipment. All McIntosh tuners will meet their published specifications when shipped from the factory.

After extensive operation, or servicing, it may be desirable to realign the tuner circuits for best performance. The charts below give complete information on the circuit realignment procedure for the MX 112.

The test equipment listed (or its equivalent) is necessary to properly align an MX 112. The accuracy of the alignment will be directly related to the accuracy and calibration of the test equipment used.

If the necessary test equipment is not available, alignment should not be attempted. For additional information, contact Customer Service Department, McIntosh Laboratory Inc., 2 Chambers Street, Binghamton, New York 13903 (telephone 607-723-3512).

Alignment should be done in the following order: AM-FM-MPX

TEST EQUIPMENT REQUIRED

1. FM Signal Generator (Measurements 188 or equivalent)
2. AM Signal Generator (Measurements 65B or equivalent)
3. VTVM
4. Multiplex Generator (RCA WR-51A or equivalent)
5. 10.7MHz Generator (preferably crystal controlled)
6. Oscilloscope (Hewlett-Packard 120B or equivalent)
7. Harmonic Distortion Analyzer (Hewlett-Packard 333A or equivalent)

AM ALIGNMENT

STEP	TUNER DIAL SETTING	SIGNAL GENERATOR			INDICATOR		ADJUST	TEST LIMITS	REMARKS
		FREQ.	COUPLING	MODULATION	TYPE	CONNECTED TO			
1	Point of no interference or signal	455kHz	Through external .01µF capacitor to junction of C4,3 and T10 pin 2.	CW	VTVM	Junction of C55 and sliding arm of AM level pot.	Maximum possible positive voltage	Switch input selector to FM to make AM local oscillator inoperative. As the tuner output increases, attenuate generator output to keep tuner output at minimum.	
2	600kHz	600kHz	Through a 200pF capacitor to ant. terminals.	Same	Same	Same	Maximum possible voltage	Same as step 1 except input selector is on AM.	
3	1400kHz	1400kHz	Same	Same	Same	Same	Same	Repeat steps 2 & 3 until dial calibration is accurate.	
4	600kHz	600kHz	Same	Same	Same	Same	Same	Same as step 1 except input selector is on AM.	
5	1400kHz	1400kHz	Same	Same	Same	Same	Same	Repeat steps 4 & 5 until output is as high as possible.	
6	1000kHz	1000kHz	Same	30% @ 400Hz	Distortion Analyzer	L or R output	With a distortion analyzer, the following measurements can be performed: 1. IHFM sensitivity of 10 microvolts for -20dB of signal to noise ratio. (this measurement is only possible in the absence of man-made interference, as fluorescent lamps, etc.) 2. With a 1mV input signal, harmonic distortion, whistle filter attenuation at 10kHz modulating frequency and signal to noise ratio may be measured. 3. With a 1mV input signal adjust "AM Level" control (R49) for .30 volt of audio output at tape-outputs.		

FM ALIGNMENT

STEP	TUNER DIAL SETTING	SIGNAL GENERATOR			INDICATOR		ADJUST	TEST LIMITS	REMARKS
		FREQ.	COUPLING	MODULATION	TYPE	CONNECTED TO			
1	Point of no interference or signal	10.7MHz	T0 TP-3	FM +200kHz at 50Hz rate	Oscilloscope	TP #1	Optimum symmetry about 10.7 MHz and 10.7MHz ± 75kHz markers.	If sweep generator has no built-in markers, use external marker generator by mixing with swept IF-signal at TP#3. First adjust Pri. and Sec. tuning slugs of T2,3,4,5 for maximum amplitude. Note this amplitude on the scope. Then, readjust T3 and T4 (T2 and T5 if necessary) for 220kHz bandwidth and optimum symmetry, taking care that amplitude of scope pattern shall not decrease by more than 30%. Hold input	

Point of reference or signal	10.7MHz	100 TP-3	at 50Hz rate	scope	bottom (primary) cores of T1, T2, T3, T4	about 10.7 MHz and 10.7MHz ± 75kHz markers.	Sec. tuning slugs of T2, 3, 4, 5 for maximum amplitude. Note this amplitude on the scope. Then, readjust T3 and T4 (T2 and T5 if necessary) for 220kHz bandwidth and optimum symmetry, taking care that amplitude of scope pattern shall not decrease by more than 30%. Hold input signal to a low level to prevent limiting.
1	Same	Same	CW	VTVM	Pin 6 of T6	Maximum possible negative voltage	
2	Same	Same	Same	Same	TP #2	Adj. for 0 volts	
3	105MHz	300 ohm antenna terminals w/matching network	400 cycles 75kHz deviation	VTVM and scope connected to L or R audio output	Oscillator Trimmer (C14)	Maximum negative voltage	As the tuner output increases, attenuate generator output to keep TP #1 voltage at a low level.
4	90MHz	Same	Same	Same	Oscillator Coil (L5)	Same	Repeat steps 4 and 5 until dial calibration is accurate.
5	105MHz	Same	Same	Same	Mixer trimmer, RF trimmer & antenna trimmer C11, C6, C2	Same	
6	90MHz	Same	Same	Same	Mixer, RF, and antenna coil tuning slugs L4, L3, L2	Same	Repeat steps 6 and 7 until TP#1 voltage is as high as possible. Connect a distortion analyzer to output jacks (either main or tape) and apply a 1mV input signal. Measure harmonic distortion and adjust T6 (primary) bottom slug for minimum distortion. (Should be less than 0.5%).
7	105MHz & 90MHz	Same	Same	VTVM connected to TP #1 and scope connected to L or R audio output.	Connect distortion analyzer to L or R output and reduce signal at antenna for -30dB total distortion and noise. Input signal required is IHFM usable sensitivity of the tuner (2.5 microvolts).	Same	Step 8 is an overall sensitivity check. Adjust muting control (R105) by reducing the signal input to 5 microvolts for a 2dB drop in audio output. Push in muting button (S302E) for this adjustment.
8	100MHz	100MHz	19kHz pilot	AC-VTVM	L105 (SCA ADJ.)	Minimum output @ L or R output jack	L105 (SCA adj.) is adjusted for minimum output with 67kHz modulation.

MULTIPLEX DECODER ALIGNMENT

STEP	TUNER DIAL SETTING	SIGNAL GENERATOR		INDICATOR		ADJUST	TEST LIMITS	REMARKS
		FREQ.	COUPLING	MODULATION	TYPE			
1	100MHz	100MHz	300Ω antenna terminals w/ approx. 1000 microvolts signal w/** matching network	75kHz Deviation @ 67kHz	AC-VTVM	L or R output jack	Minimum output @ L or R output jack	L105 (SCA adj.) is adjusted for minimum output with 67kHz modulation.
	100MHz	100MHz	Same	19kHz pilot	AC-VTVM	T101, pin 2	Adjust for	Decrease pilot level so that 19kHz circuits are

7	105MHz & 90MHz	105MHz & 90MHz	Same	Same	VTVM connected to TP #1 and scope connected to L or R audio output.	Slugs L1, L3, L2	Connect distortion analyzer to L or R output and reduce signal at antenna for -30dB total distortion and noise. Input signal required is IHFM usable sensitivity of the tuner (2.5 microvolts).	apply a 1mv input signal. Measure harmonic distortion and adjust T6 (primary) bottom slug for minimum distortion. (Should be less than 0.5%).
8	100MHz	100MHz	Same	Same	VTVM connected to TP #1 and scope connected to L or R audio output.		Step 8 is an overall sensitivity check. Adjust muting control (R105) by reducing the signal input to 5 microvolts for a 2dB drop in audio output. Push in muting button (S302E) for this adjustment.	

MULTIPLEX DECODER ALIGNMENT

STEP	TUNER DIAL SETTING	SIGNAL GENERATOR			INDICATOR		ADJUST	TEST LIMITS	REMARKS
		FREQ.	COUPLING	MODULATION	TYPE	CONNECTED TO			
1	100MHz	100MHz	300P antenna terminals w/ approx. 1000 microvolts signal w/** matching network	75kHz Deviation @ 67kHz	AC-VTVM	L or R output jack	L105 (SCA ADJ.)	Minimum output @ L or R output jack	L105 (SCA adj.) is adjusted for minimum output with 67kHz modulation.
2	100MHz	100MHz	Same	19kHz pilot	AC-VTVM or oscilloscope w/very low cap. probe	T101, pin 2 or 3.	L102 (19kHz phase adj.) & T101 (19 kHz doubler)	Adjust for maximum AC voltage	Decrease pilot level so that 19kHz circuits are not being saturated.
3	Same	Same	Same	Same	Same	T102, Pin 1 or 2.	T102 (Pri) & bottom (Sec) tuning slugs	Adj. for maximum AC voltage	Decrease pilot level so that 19kHz and 38kHz circuits are not being saturated. Mode switch must be in stereo position.
4	Same	Same	Same	1kHz (100% modulation) L or R only, pilot on	Same	L or R output jack	T102, Bottom (Sec.) tuning slug.	30dB separation or more	First, modulate left channel and measure right channel output. Adjust T102 bottom - tuning slug (Sec.) for minimum right channel output. (maximum separation) Then, reverse channels and measure left channel separation. For this adjustment and measurement, no test lead should be connected to TP#2, and the dust cover over this section should be in place.
5	100MHz	100MHz	Same	1kHz (100% modulation) L or R only, pilot on	AC-VTVM	L or R output jack		Less than 10mV volts of residual dual	Adjust "FM-Level" control (R107) for 1 volt of audio output at tape-outputs. Then, turn off the modulation and measure the residual of the 10kHz and 38kHz frequencies.

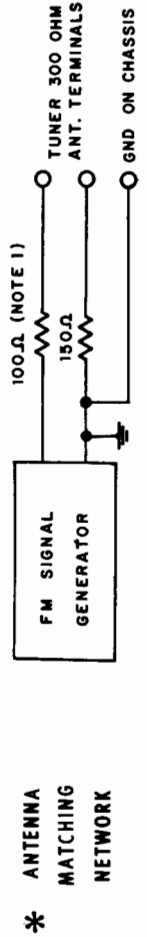

Note.1 : If signal generator has other than 50 ohm internal impedance, use a resistor of 150 ohms less internal generator impedance.

REPLACEMENT PARTS

All parts not listed are common items obtainable from radio parts jobbers.

Replacement parts may be obtained when ordered by PART NUMBER from:

McIntosh Laboratory Inc.
Customer Service Department
2 Chambers Street
Binghamton, New York 13903
(telephone 607-723-3512)

CAPACITORS

Symbol Number	Description	Part Number
C56	Mylar .22 μ F 250V	064-068
C58,59	Elect. 100 μ F 15V	066-127
C101	Mylar .22 μ F 250V	064-068
C107	Elect. 100 μ F 15V	066-127
C111	Mylar .1 μ F 250V	064-067
C113	Mylar .22 μ F 250V	064-068
C127	Elect. 100 μ F 15V	066-127
C201	Elect. 100 μ F 25V	066-124
C202	Mylar .22 μ F 250V	064-068
C204	Elect. 200/200 μ F 100V	066-129
C205,206	Mylar .22 μ F 250V	064-068
C207	Mylar .47 μ F 250V	064-069
C208,209	Elect. 100 μ F 15V	066-127
C210	Elect. 50/200/300/150 μ F 200/150/50/50V	066-218
C301,302	Mylar .47 μ F 250V	064-069
C305,306	Elect. 10 μ F 20V	066-149
C307,308	Elect. 10 μ F 20V	066-149
C315,316	Elect. 100 μ F 15V	066-127
C317,318	Mylar .47 μ F 250V	064-069
C319,320	Mylar .22 μ F 200V	064-087
C323,324	Mylar .047 μ F 250V	064-066
C325,326	Mylar .47 μ F 250V	064-069
C327	Mylar .47 μ F 250V	064-069
C329,330	Mylar .047 μ F 250V	064-066
C331,332	Mylar .022 μ F 250V	064-065
C337,338	Mylar .1 μ F 250V	064-067
C339,340	Mylar .47 μ F 250V	064-069
C341,342	Mylar .047 μ F 250V	064-066
C343,344	Mylar .47 μ F 250V	064-069

DIODES

D1,2	Si. signal diode	070-022
D3,4	Si. signal diode	070-022

D5	Ge. signal diode	070-003
D6,7	Si. signal diode	070-022
D101,102	Si. signal diode	070-022
D103	Si. signal diode	070-022
D104	Ge. signal diode	070-003
D105,106	Ge. signal diode	070-003
D107	Ge. signal diode	070-003
D108	Bias diode	070-046
D201	Zener diode 16V	070-042
D202,203	Si. rectifier	070-031
D205,206	Si. rectifier	070-031
D207	Zener diode 75V	070-025

FUSE

F201	Fuse .5 amp Slo-blo	089-020
------	---------------------	---------

CHOKES

L1	Choke 1.2 μ H	122-011
L2	FM antenna coil	122-069
L3	FM RF coil	122-070
L4	FM mixer coil	122-071
L5	FM local oscillator coil	122-072
L6	AM loop antenna	122-074
L7	AM antenna coil	122-073
L10	Choke 75 μ H	122-013
L12	AM oscillator coil	122-066
L13	Choke 100mH	122-004
L14	Choke 1.2 μ H	122-011
L101	Choke 1mH	122-065
L102	Filter coil (19kHz phase)	122-067
L103,104	Filter coil (lo pass)	122-015
L105	Filter coil (SCA adjust)	122-068

TRANSISTORS

Q1	Si. junction F.E.T.	132-049
Q2,3	Si. junction F.E.T.	132-049
Q4	M.O.S. F.E.T.	132-064
Q5,6	Si. NPN transistor	132-015
Q7	Si. junction F.E.T.	132-049
Q8	M.O.S. F.E.T.	132-064
Q9,10	M.O.S. F.E.T.	132-061
Q11	Si. NPN transistor	132-041
Q101	Si. NPN transistor	132-057
Q102	Si. NPN transistor	132-052
Q103	Si. NPN transistor	132-041

Q104,105
Q106
Q201
Q202
Q203
Q301,302
Q303,304
Q305,306
Q307,308
Q309,310
Q311,312
Q313,314
Q315,316

R49
R105
R107
R335
R356
R377,378

R219
R220
R221

S1
S202
S301
S302
S303

T1
T2
T3
T4
T5
T6
T7,8
T9
T10
T101

Q104,105	Si. NPN transistor	132-057
Q106	Si. NPN transistor	132-042
Q201	Si. NPN transistor	132-072
Q202	Si. NPN transistor	132-516
Q203	Si. NPN transistor	132-069
Q301,302	Si. PNP transistor	132-056
Q303,304	Si. PNP transistor	132-056
Q305,306	Si. NPN transistor	132-069
Q307,308	Si. NPN transistor	132-054
Q309,310	Si. PNP transistor	132-056
Q311,312	Si. NPN transistor	132-054
Q313,314	Si. NPN transistor	132-057
Q315,316	Si. NPN transistor	132-042

POTENTIOMETERS

R49	AM level	134-177
R105	Muting adjust	134-216
R107	FM level	134-197
R335	Volume control	134-202
R356	Balance control	134-201
R377,378	Tone control	134-203

RESISTORS

R219	Wirewound 2.0 Ω 5W	139-005
R220	Wirewound 2.7 Ω 1W	139-002
R221	Wirewound 1.2 Ω 1W	139-001

SWITCHES

S1	AM sensitivity	148-023
S202	Dial scale intensity	148-023
S301	Input selector	146-125
S302	Pushbutton	150-004
S303	Phase	148-023

TRANSFORMERS

T1	Balun	043-226
T2	FM IF transformer	162-034
T3	FM IF transformer	162-035
T4	FM IF transformer	162-034
T5	FM IF transformer	162-035
T6	FM discriminator	162-036
T7,8	AM IF transformer	162-038
T9	AM IF transformer	162-038
T10	AM RF transformer	162-033
T101	RF transformer (19kHz)	162-031

T102	RF transformer (38kHz)	162-031
T201	Power transformer	043-86

TUBES

V1	6HU6	165-02
----	------	--------

INTEGRATED CIRCUITS

IC1,2	Integrated circuit	133-00
-------	--------------------	--------

MODULES

	Tone control module	130-02
--	---------------------	--------

LAMPS

	#1828 (MPX lamp)	058-02
	#1866 (front panel)	058-01
	Festoon lamp (dial glass)	058-03

FRONT PANEL & TRIM

	Front panel	043-92
	Front panel end caps	018-12
	Tuning knob	043-27
	Volume control knob	043-25
	Balance knob	043-25
	Input selector knob	043-25
	Bass knob (rear)	090-00
	Bass knob (front)	043-62
	Treble knob (rear)	090-00
	Treble knob (front)	043-62
	Muting knob	090-01

MOUNTING SYSTEM

	Shelf bracket (right)	043-59
	Shelf bracket (left)	043-59
	Mounting template #100	038-17
	Hardware package	043-44

MISCELLANEOUS ITEMS

	FM dipole antenna	170-03
	Dial glass	043-89
	Pointer	043-87
	Dial cord (complete)	043-89
	Fuseholder	178-00
	AC power cord	170-02
	Shipping carton	043-94
	Owners manual	038-44
	Plastic feet	017-04
	Push terminal (antenna)	074-03

T102	RF transformer (38kHz)	162-039
T201	Power transformer	043-865
TUBES		
V1	6HU6	165-025
INTEGRATED CIRCUITS		
IC1,2	Integrated circuit	133-001
MODULES		
	Tone control module	130-027
LAMPS		
	#1828 (MPX lamp)	058-027
	#1866 (front panel)	058-014
	Festoon lamp (dial glass)	058-032
FRONT PANEL & TRIM		
	Front panel	043-920
	Front panel end caps	018-120
	Tuning knob	043-272
	Volume control knob	043-253
	Balance knob	043-253
	Input selector knob	043-253
	Bass knob (rear)	090-009
	Bass knob (front)	043-625
	Treble knob (rear)	090-009
	Treble knob (front)	043-625
	Muting knob	090-010
MOUNTING SYSTEM		
	Shelf bracket (right)	043-592
	Shelf bracket (left)	043-593
	Mounting template #100	038-179
	Hardware package	043-446
MISCELLANEOUS ITEMS		
	FM dipole antenna	170-033
	Dial glass	043-897
	Pointer	043-876
	Dial cord (complete)	043-891
	Fuseholder	178-001
	AC power cord	170-021
	Shipping carton	043-949
	Owners manual	038-447
	Plastic feet	017-041
	Push terminal (antenna)	074-032

Shorting plug	127-001
Audio cable (6')	170-015
LDR network	144-013

FRONT GLASS ONLY - 016-054-25.00

SERVICE BULLETIN

AM NOISE REDUCTION MODIFICATION

MODEL: MX 112 FM/AM Tuner-Preamp

PURPOSE OF MODIFICATION: To improve AM signal to noise ratio.

WHAT UNITS ARE AFFECTED: Serial No. 10S01 to 43S90 Only.

WHEN MODIFICATION SHOULD BE MADE: When customer complains that AM is noisy on local stations or that sensitivity is poor.

McINTOSH MODIFICATION KIT NO.: No kit.

PARTS REQUIRED:

QUANTITY	PART NUMBER	DESCRIPTION
1	061-043	.01 μ F +80-20% Disc capacitor

PROCEDURE:

- Step 1 Remove bottom cover, Multiplex-AM top cover, and RF front end bottom cover. Remove capacitors C204 and C208 on AM PC board. See service manual for exact location. Replace top cover.
- Step 2 Locate Q4, AM RF amplifier in RF front end chassis. Connect the .01 μ F disc capacitor between the source terminal of Q4 and the ground lug of the terminal strip as shown in the accompanying sketch. Replace bottom covers.
- Step 3 Check performance. If dial calibration is off at high end of the band, perform AM alignment steps 3 and 5 in service manual. The top cover of the RF front end is removed for access to the alignment trimmers.

(over)

BOTTOM VIEW

RF CHASSIS

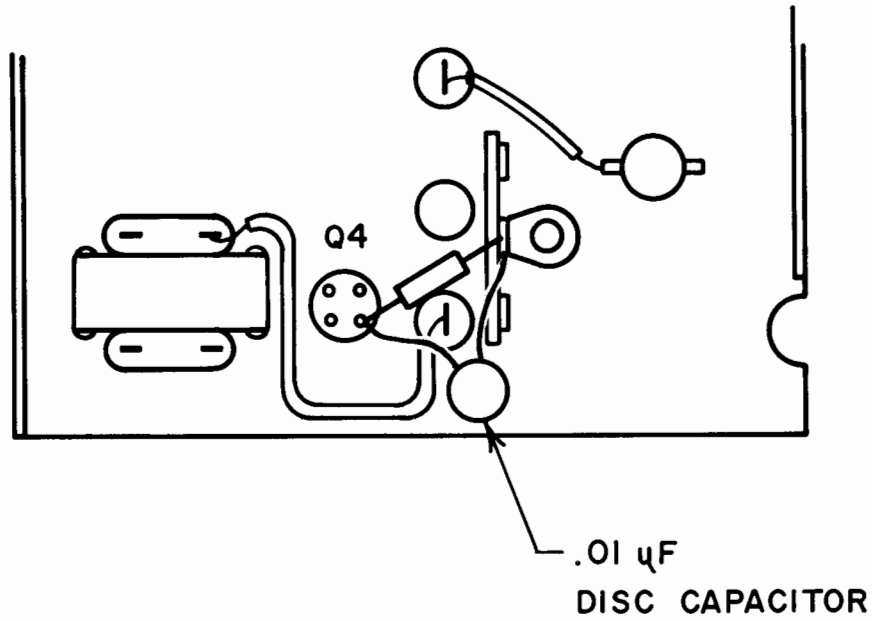

FRONT OF UNIT

McIntosh SERVICE BULLETIN

SCA FILTER MODIFICATION

MODEL: MX 112 Tuner Preamplifier

PURPOSE OF MODIFICATION: To increase effectiveness of SCA filter.

WHAT UNITS ARE AFFECTED: Serial No. 10S01 to 31S55 only.

WHEN MODIFICATION SHOULD BE MADE: When a customer complains of "birdies", whistles, or other noises on certain multiplex stations.

McINTOSH MODIFICATION KIT NO. : No kit available.

PART REQUIRED:

Quantity	Description
1	150pF 20% Ceramic Disc Capacitor RMC type JG or equal.

PROCEDURE:

- Step 1 Remove bottom cover of the MX 112.
- Step 2 Remove the perforated cover from the MPX section.
- Step 3 Solder the capacitor in parallel with R129, a 47k resistor that connects between the SCA filter and the base of Q102. Keep leads short.
- Step 4 Feed a 1 volt 67 kHz signal from an audio oscillator into TP #2 of the MX 112. Observe the signal on a scope at the tape output. Adjust the SCA filter for minimum 67 kHz in the output.
- Step 5 Replace the covers.

038-375